

Panascope®

ROUTINE METALLURGICAL
MICROSCOPE

PM-70



Panascope®

Copyright © 2024 Panascope Co.,Ltd. All rights reserved. Printed in the Singapore.
Panascope Co.,Ltd. reserves the right to change and improve specifications with out
notice due to technological or manufacturing advances.

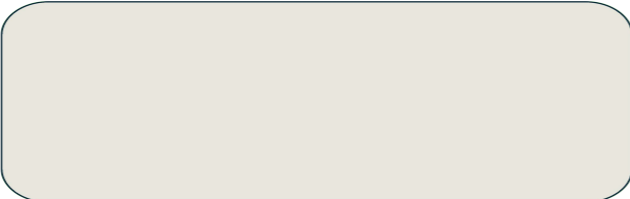



More suitable LED lighting

LED lighting provides illumination for bright field, oblique lighting, polarization and other viewing methods, and the color temperature is adjustable, which can provide true color images in all brightness levels. Long service life, no need to change the bulb frequently. Low heat generation, no risk of overheating, no need for cold fans, creating a quiet and uninterrupted working environment. Due to the advantages of LED lighting sources, it is replacing traditional halogen light sources and becoming the first choice for microscope light sources.

Always maintain a stable color temperature

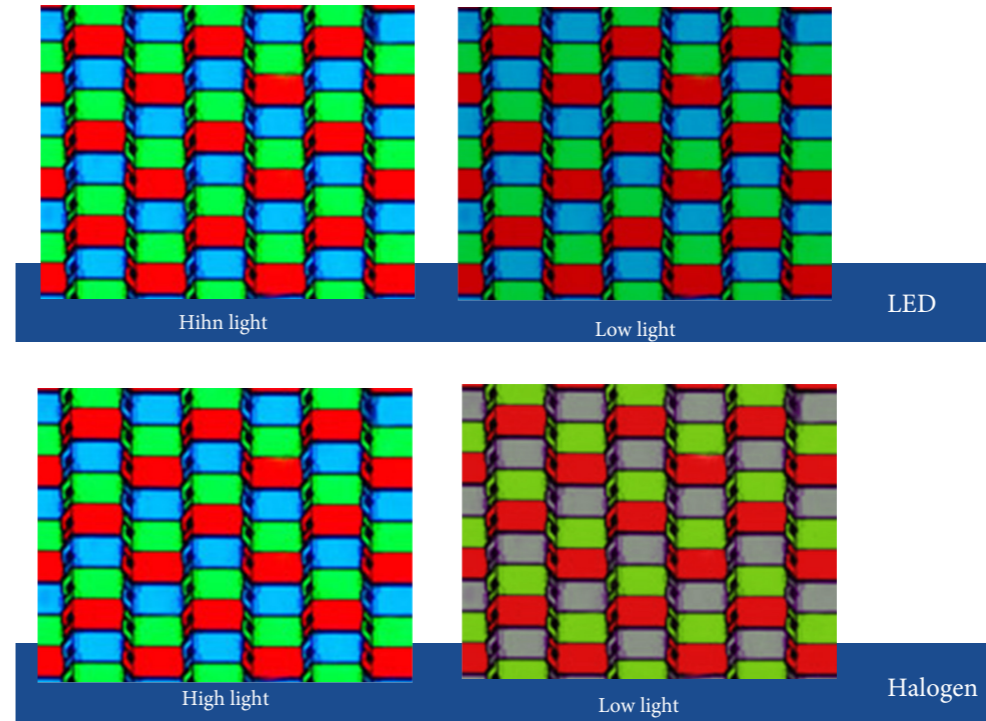

PM-70

ROUTINE METALLURGICAL MICROSCOPE

The PM-70 is designed for you who need to work in front of a microscope every day. The transreflective light sources are illuminated by leds with adjustable color temperatures, providing a true color image at all brightness levels. With the display and coded objective converter and light source, the microscope operation is simple and clear. It can meet the requirements of metallography, earth science, forensic examination, sampling quality control and material research, and realize the functions of photo shooting, data analysis and image display with the metallographic software platform. This is a true metallurgical microscope for every environment, fully functional, simple to use and easy to maintain.

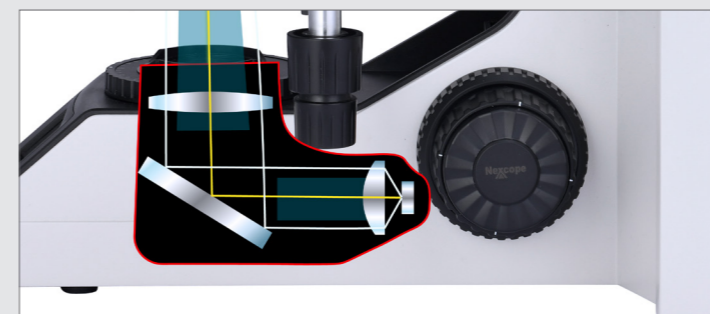

Built-in LED transmission light source

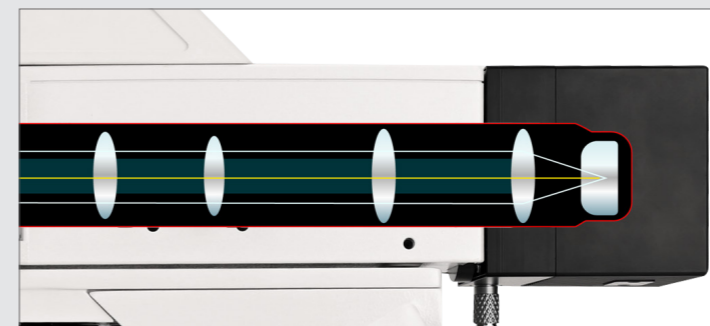

LED reflected light source



Detail design to make work easier



Break through the conventional light source conversion mode

Both the transmitted light source and the reflected light source are linked with the multi-function turntable, and the light source conversion is more convenient than the conventional push-button switch button, which is more suitable for beginners.



Microscope status display function

The LCD screen at the front of the microscope can display the use state of the microscope, including magnification, light intensity, color temperature, light source state, etc.

Main interface

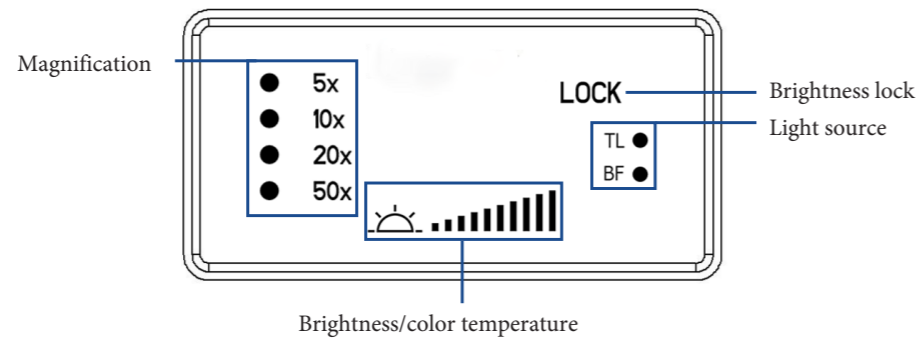

Brightness memory function

It can remember the lighting brightness when using each objective lens, and automatically adjust the light intensity when different objectives are converted to each other, reducing visual fatigue and improving work efficiency.

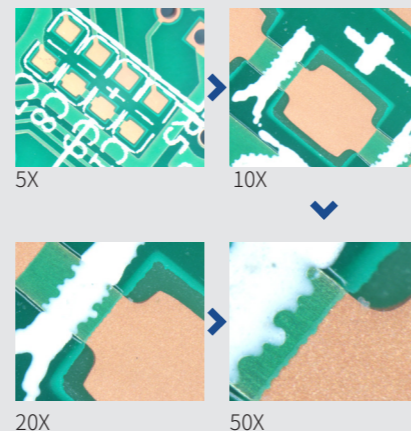

Meet the daily material inspection needs



In addition to the traditional reflected and transmitted bright fields, oblique illumination and polarization can also be selected to increase the imaging contrast, so that this microscope is suitable for more applications, such as pharmaceutical chemical engineering, materials research, quality assessment, cleanliness analysis, public inspection and so on.

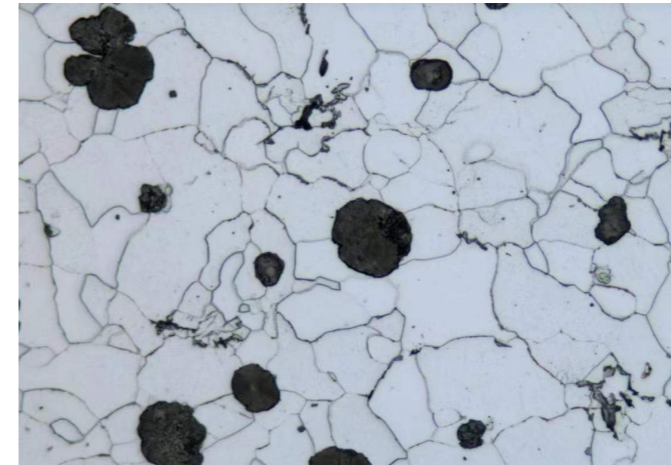

Reflection Bright Field

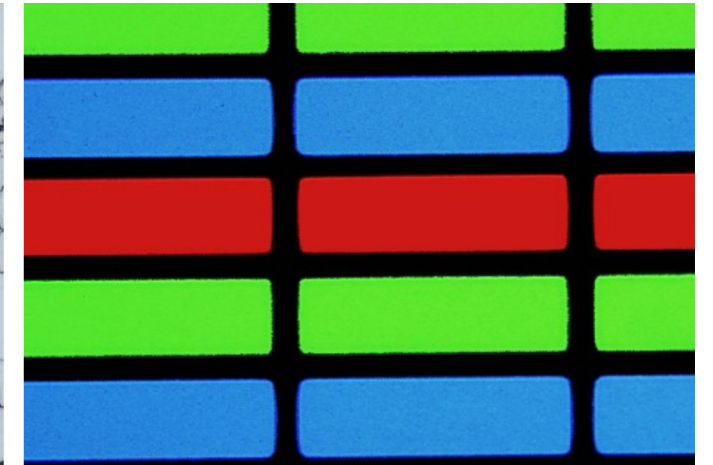

Transmission Bright Field



OIC

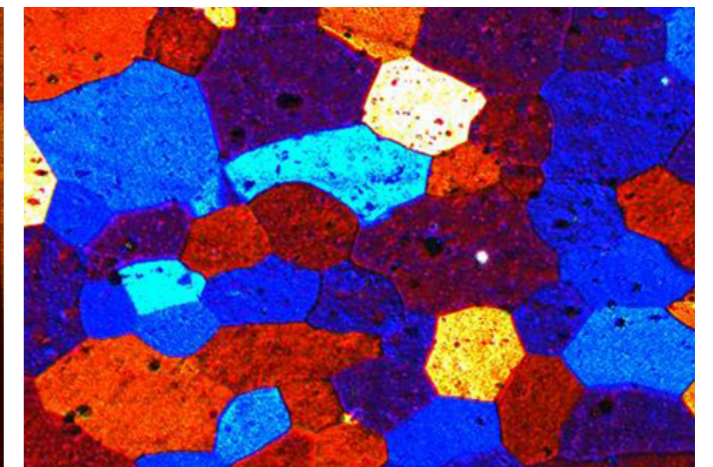

Polarization



A variety of objectives for you to choose from

We offer 2.5X-100X objective lenses for all viewing methods. Use the 2.5x overview objective to identify macroscopic structures in the sample, switch to 100x to observe alloy edges and material cracks. The conversion of different observation methods allows you to understand your sample in detail.

Easy and powerful software platform

NOMIS Basic's simple user interface guides users step by step through acquisition, adjustment, measurement and reporting. At the same time, it is a software system that can meet the micro-observation needs of users in the process of using the microscope at any time.

Image stitching

NOMIS Basic offers manual stitching to provide panoramic images of samples beyond the field of view. By acquiring images in real time or importing images, they can be quickly spliced to form a large-size, high-resolution image

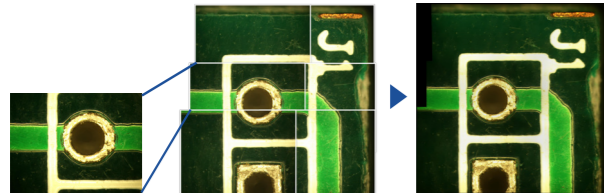

Real time/static measurement

Typical observations and quality control require interactive measurement functions such as: distance, Angle, rectangle, circle, and ellipse. All measurement data of this system can be exported to Microsoft Excel tables.

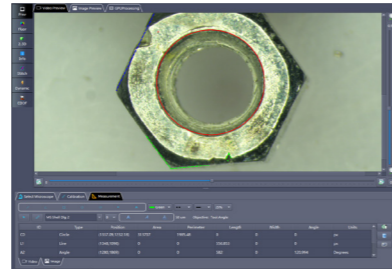

Depth of field fusion /3D reconstruction

NOMIS Basic offers depth of field fusion and 3D reconstruction capabilities, and both can be used in real-time HDR mode. After using the Depth of Field fusion function, the user gets a 3D reconstructed model, which can be imported and displayed in the 2.5D module.

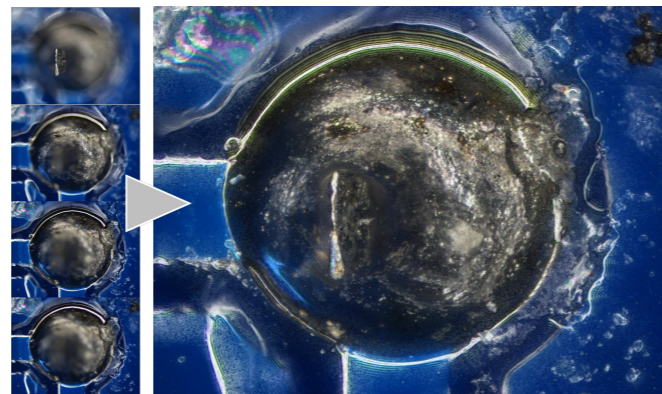

Hd real-time HDR images/video

When different samples are observed, the sample surface will show areas of high contrast. NOMIS Basic provides real-time high dynamic range observation technology based on GPU-accelerated software. This technique allows users to create perfectly exposed images between clicks.

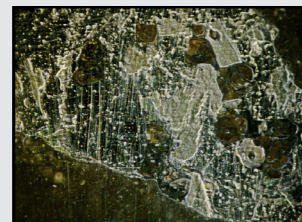
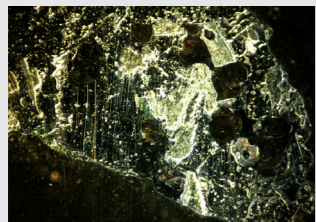

Automatic exposure image

HDR image

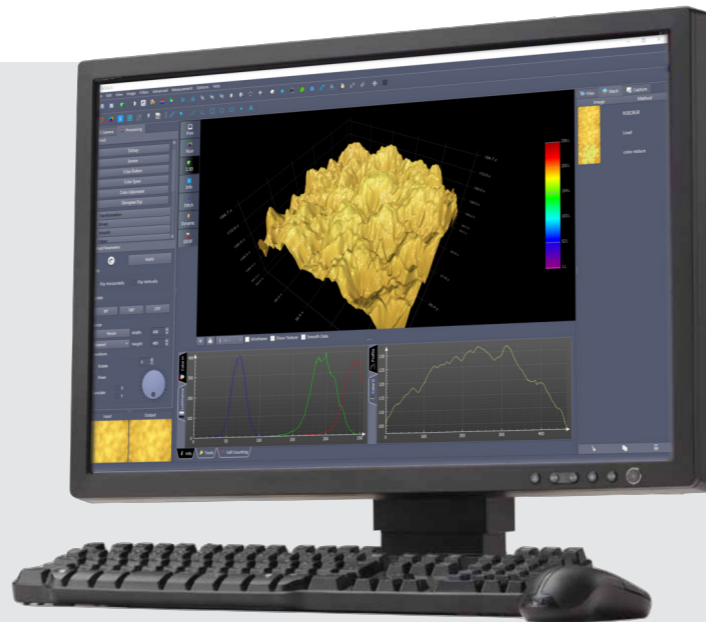

Easier handling and storage

With a special handling handle, and light weight, good stability, stable structure. The microscope backplane is designed with a concentrator device, which effectively collects the excessively long power cord, improves the cleanliness of the laboratory, and reduces the tripping accidents caused by the excessively long power cord during the handling process.



Winder



Handling handle

PM-70 Specification

Optical system	Infinite optical system
Eyepiece(FOV)	10X/22
Viewing tube	30° inclined, Infinite seidentopf binocular viewing head, interpupillary: 48-75mm 30° inclined, Infinite seidentopf trinocular viewing head, interpupillary: 48-75mm, fixedsplitting ratio R:T=50:50
Objective	Plan infinite achromatic objective
Nosepiece	Backward Quintuple Nosepiece
Stage	Double oayers mechanical stage, can equip metal carrier plate(reflected) and glass carrier plate(reflected and transmitted)
Condenser	Achromatic condenser (NA 0.9) with variable aperture stop, center adjustable, 4x-100x universal
Focusing system	Coaxial coarse and fine adjustment, has the function of coarse tightness adjustment, fine division 1 um,with stage up and down adjustment mechanism
Illumination	Transmission
	Reflection
Video/Photo attachment	1X, 0.5X C mount